

# 男子シングルス

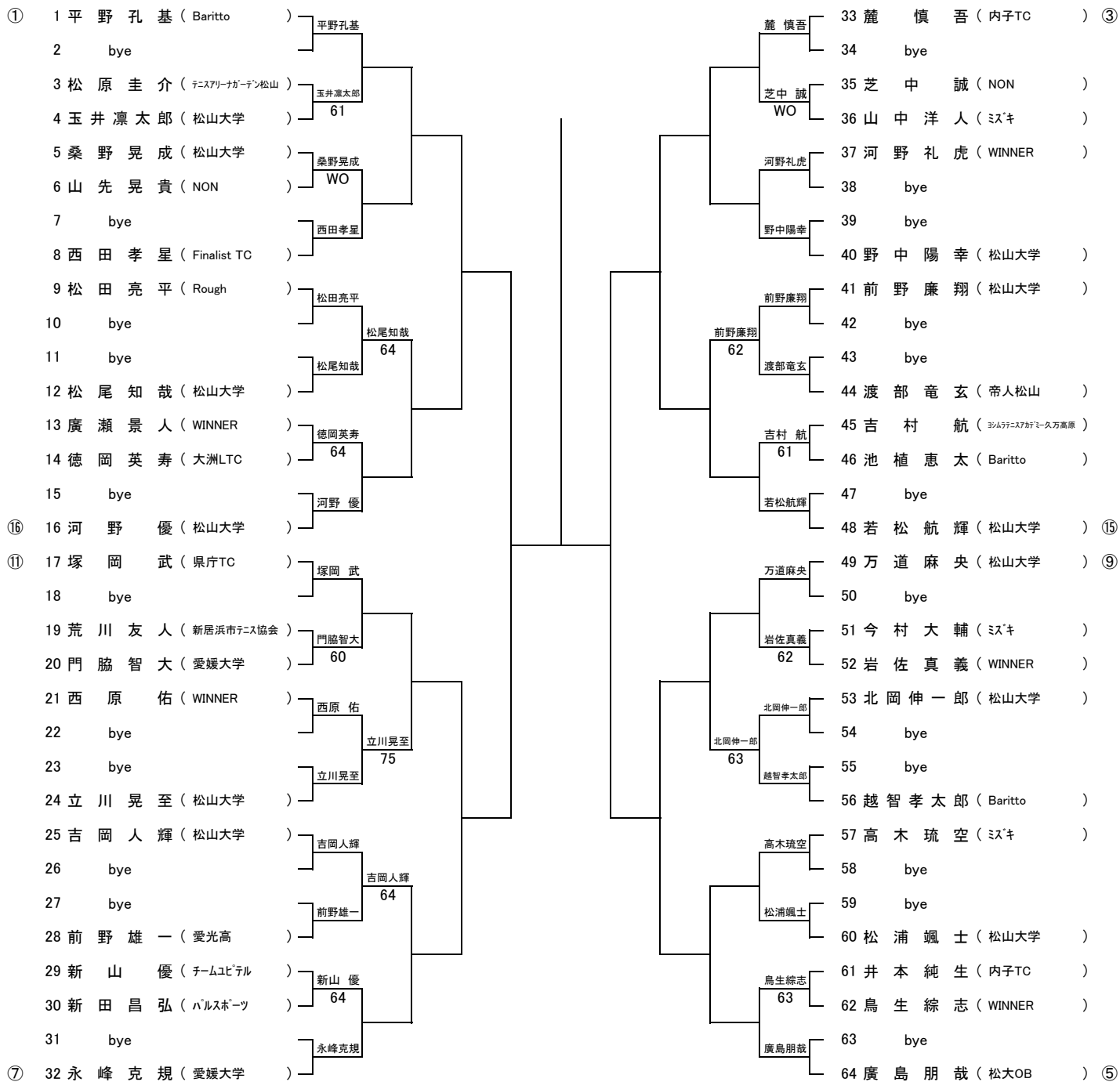

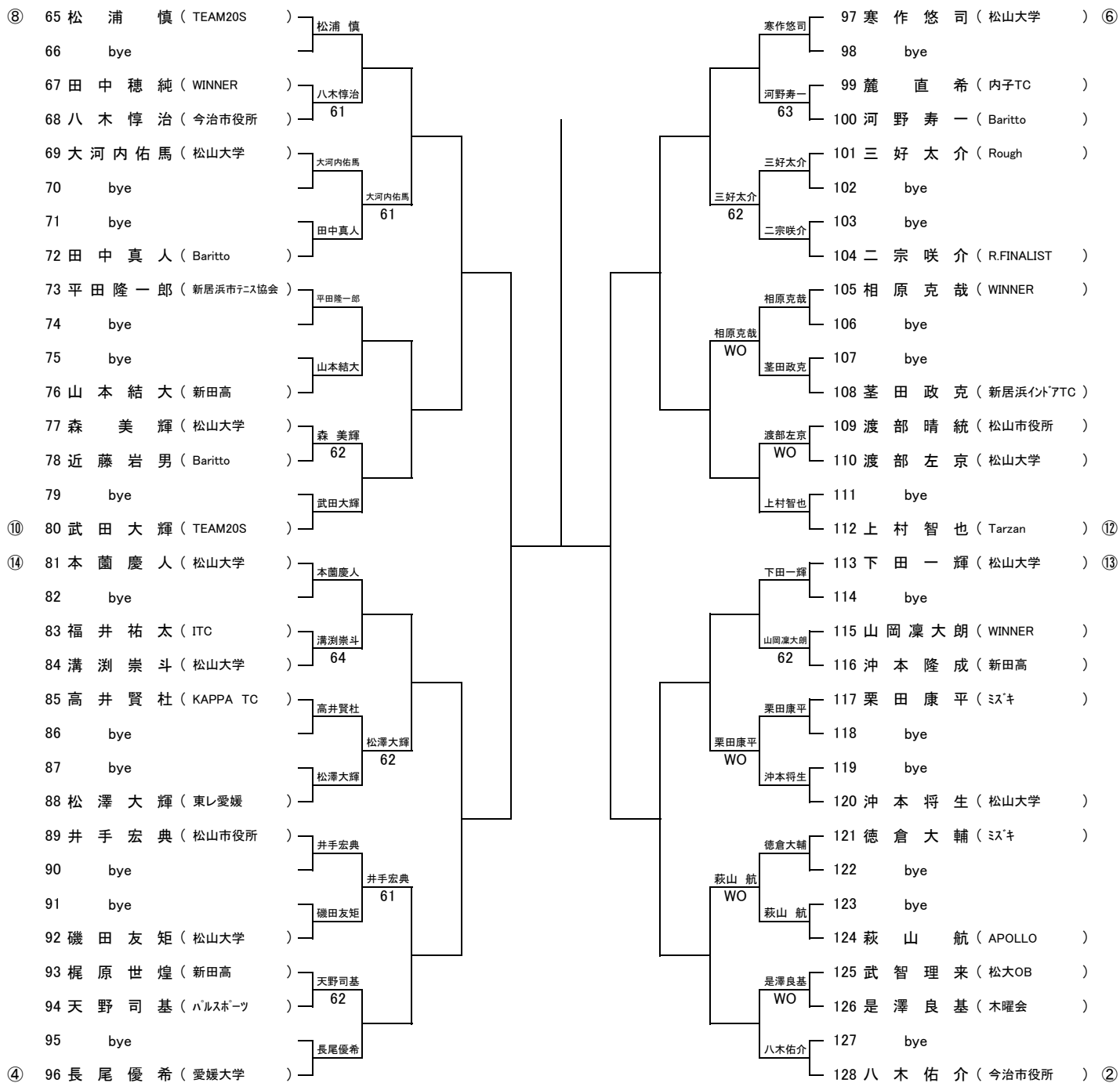

決勝

1~64

65~128

